

# Résidence "ELENA II"

COMMUNE DE BASTIA

BATIMENT 5 - LOT 9 - DUPLEX - TYPE 4

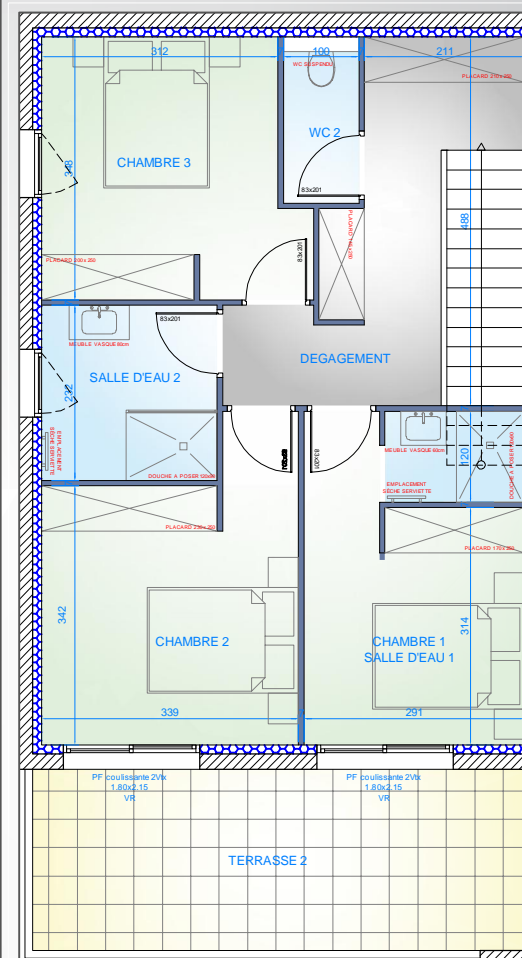
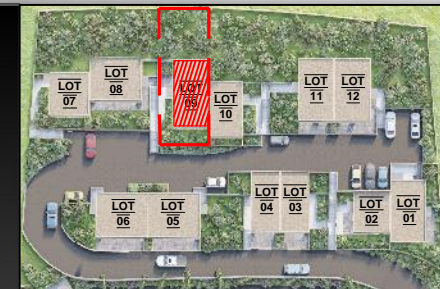

NIVEAU 1 - COIN NUIT

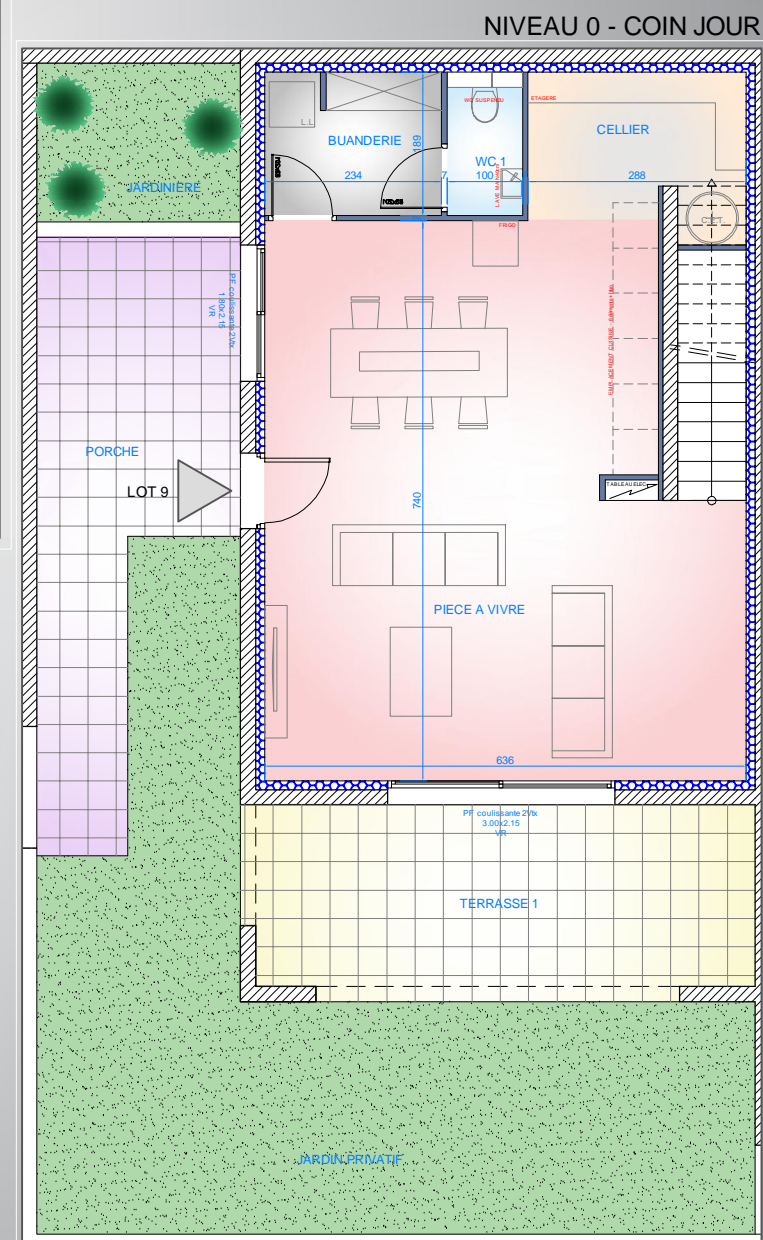
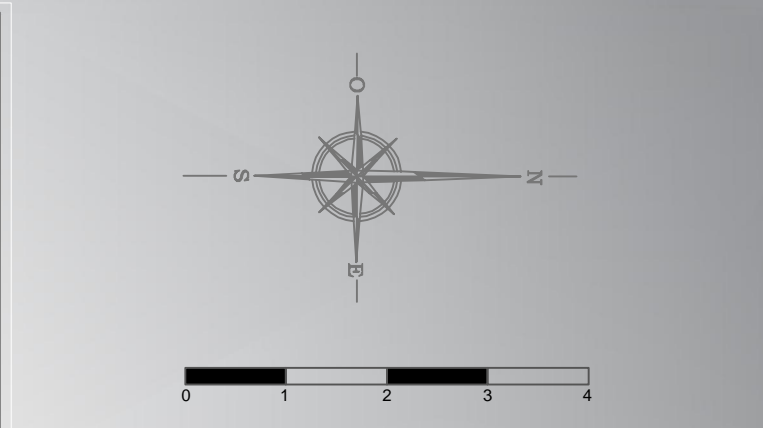

NIVEAU 0 - COIN JOUR

TABLEAU DES SURFACES  
BATIMENT 5 - LOT 9 - T4 - duplex

NIVEAU 0	PIECE A VIVRE	41.69m <sup>2</sup>
	CELLIER	5.60m <sup>2</sup>
	BUANDERIE	4.42m <sup>2</sup>
	WC 1	1.69m <sup>2</sup>
NIVEAU 1	DEGAGEMENT	9.87m <sup>2</sup>
	CHAMBRE 1 - SALLE D'EAU 1	12.35m <sup>2</sup>
	CHAMBRE 2	12.56m <sup>2</sup>
	CHAMBRE 3	11.04m <sup>2</sup>
	SALLE D'EAU 2	5.34m <sup>2</sup>
	WC 2	2.00m <sup>2</sup>
TOTAL		106.56m <sup>2</sup>
PORCHE - PALLIER		15.70m <sup>2</sup>
TERRASSE 1		16.87m <sup>2</sup>
TERRASSE 2		15.57m <sup>2</sup>
JARDIN PRIVATIF EN PLANCHES ESPACE VERT		env. 115.00m <sup>2</sup>